

martin®

Martin®
V-Plow HD



Operator's Manual
M3201

Important

MARTIN ENGINEERING HEREBY DISCLAIMS ANY LIABILITY FOR: DAMAGE DUE TO CONTAMINATION OF THE MATERIAL; USER'S FAILURE TO INSPECT, MAINTAIN AND TAKE REASONABLE CARE OF THE EQUIPMENT; INJURIES OR DAMAGE RESULTING FROM USE OR APPLICATION OF THIS PRODUCT CONTRARY TO INSTRUCTIONS AND SPECIFICATIONS CONTAINED HEREIN. MARTIN ENGINEERING'S LIABILITY SHALL BE LIMITED TO REPAIR OR REPLACEMENT OF EQUIPMENT SHOWN TO BE DEFECTIVE.

Observe all safety rules given herein along with owner and Government standards and regulations. Know and understand lockout/tagout procedures as defined by American National Standards Institute (ANSI) z244.1-1982, *American National Standard for Personnel Protection - Lockout/Tagout of Energy Sources - Minimum Safety Requirements* and Occupational Safety and Health Administration (OSHA) Federal Register, Part IV, 29 CFR Part 1910, *Control of Hazardous Energy Source (Lockout/Tagout); Final Rule*.

The following symbols may be used in this manual:



Danger: Immediate hazards that will result in severe personal injury or death.



Warning: Hazards or unsafe practices that could result in personal injury.



Caution: Hazards or unsafe practices that could result in product or property damages.



Important: Instructions that must be followed to ensure proper installation/operation of equipment.



Note: General statements to assist the reader.

Table of Contents

Section	Page
List of Figures	ii
List of Tables	ii
Introduction	1
General	1
References	1
Safety	1
Materials required	1
Before Installing V-Plow	2
Installing V-Plow	3
After Installing V-Plow	7
Monthly Maintenance	8
Part Numbers	9

List of Figures

Figure	Title	Page
1	Locating Martin® V-Plow HD on Belt	3
2	Martin® V-Plow HD Hanger Bar Locations	4
3	Distance Between Hanger Bars	5
4	Installing Martin® V-Plow HD	6
5	Martin® V-Plow HD Assembly, P/N 31106-XXXX (18 - 48-in. [400 - 1400-mm] belts)	10
6	Martin® V-Plow HD Assembly, P/N 31106-XXXX (54 - 96-in. [1400 - 2400-mm] belts)	12
7	Conveyor Products Warning Label, P/N 23395	15
8	Flying Objects Warning Label, P/N 38227	16

List of Tables

Table	Title	Page
I	Martin® V-Plow HD Specifications	1
II	Martin® V-Plow HD Hanger Bar Locations	4
III	Martin® V-Plow HD Item Quantities and Part Numbers	11
IV	Martin® V-Plow HD Blade Quantities	11
V	Martin® V-Plow HD Item Quantities and Part Numbers	13
VI	Martin® V-Plow HD Blade Quantities	13
VII	Martin® V-Plow HD Urethane Blade Chart	14
VIII	Martin® V-Plow HD Hanger Pivot Arm Part Numbers	14

Introduction

General

The Martin® V-Plow HD floats on the inside surface of a conveyor belt to effectively remove stray material in light- to moderate-duty applications. The self-adjusting design provides effective cleaning in all states of blade wear.

The Martin® V-Plow HD fits belts from 18 to 96 in. (400 to 2400 mm) wide. Specifications are shown in Table I.

Table I. Martin® V-Plow HD Specifications

Cleaning Edge Material	60-Durometer Rubber
	90-Durometer Urethane
Blade Dimensions	1 x 4 in. (25 x 102 mm)
Operating Temperature	-20 to 160°F (-29 to 71°C)

References

The following documents are referenced in this manual:

- American National Standards Institute (ANSI) z244.1-1982, *American National Standard for Personnel Protection - Lockout/Tagout of Energy Sources - Minimum Safety Requirements*, American National Standards Institute, Inc., 1430 Broadway, New York, NY 10018.
- Federal Register, Volume 54, Number 169, Part IV, 29 CFR Part 1910, *Control of Hazardous Energy Source (Lockout/Tagout); Final Rule*, Department of Labor, Occupational Safety and Health Administration (OSHA), 32nd Floor, Room 3244, 230 South Dearborn Street, Chicago, IL 60604.

Safety

All safety rules defined in the above documents and all owner/employer safety rules must be strictly followed when working on the Martin® V-Plow.

Materials required

Only standard hand tools are needed to install this equipment.

Before Installing V-Plow

IMPORTANT

Read entire section before beginning work.

1. Inspect the shipping container for damage. Report damage to the delivery service. Fill out the damage report and return it to Martin Engineering.
2. Remove the Martin® V-Plow HD from the shipping container. Equipment in the container should include the following:
 - Martin® V-Plow HD Assembly.
 - Conveyor Products Warning Label, P/N 23395.
 - Flying Objects Warning Label, P/N 38227.
 - Warranty card.
 - Damage report.
3. If anything is missing or damaged, contact Martin Engineering or representative. Fill out the warranty card and return it to Martin Engineering.



⚠ WARNING

Before installing equipment, turn off and lock out/tag out energy source to conveyor and conveyor accessories.

4. Turn off and lock out/tag out energy source according to ANSI standards (see “References”).

⚠ WARNING

If equipment will be installed in an enclosed area, test gas level or dust content before using a cutting torch or welding. Using a cutting torch or welding in an area with gas or dust may cause an explosion.

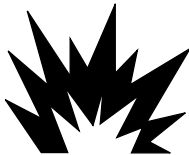

5. If using a cutting torch or welding, test the atmosphere for gas level or dust content. Cover the conveyor belt with a fire-retardant cover.

IMPORTANT

Read entire section before beginning work.

⚠ CAUTION

Position v-plow blade according to chart in Figure 1. Minimum distance is to ensure safety cables will keep v-plow from damaging tail pulley or conveyor belt if mount brackets fail.

1. Place the Martin® V-Plow HD blade (A, Figure 1) on the return side of the belt before the tail pulley (B), with the “V” pointing away from the tail pulley. Position according to chart in Figure 1.

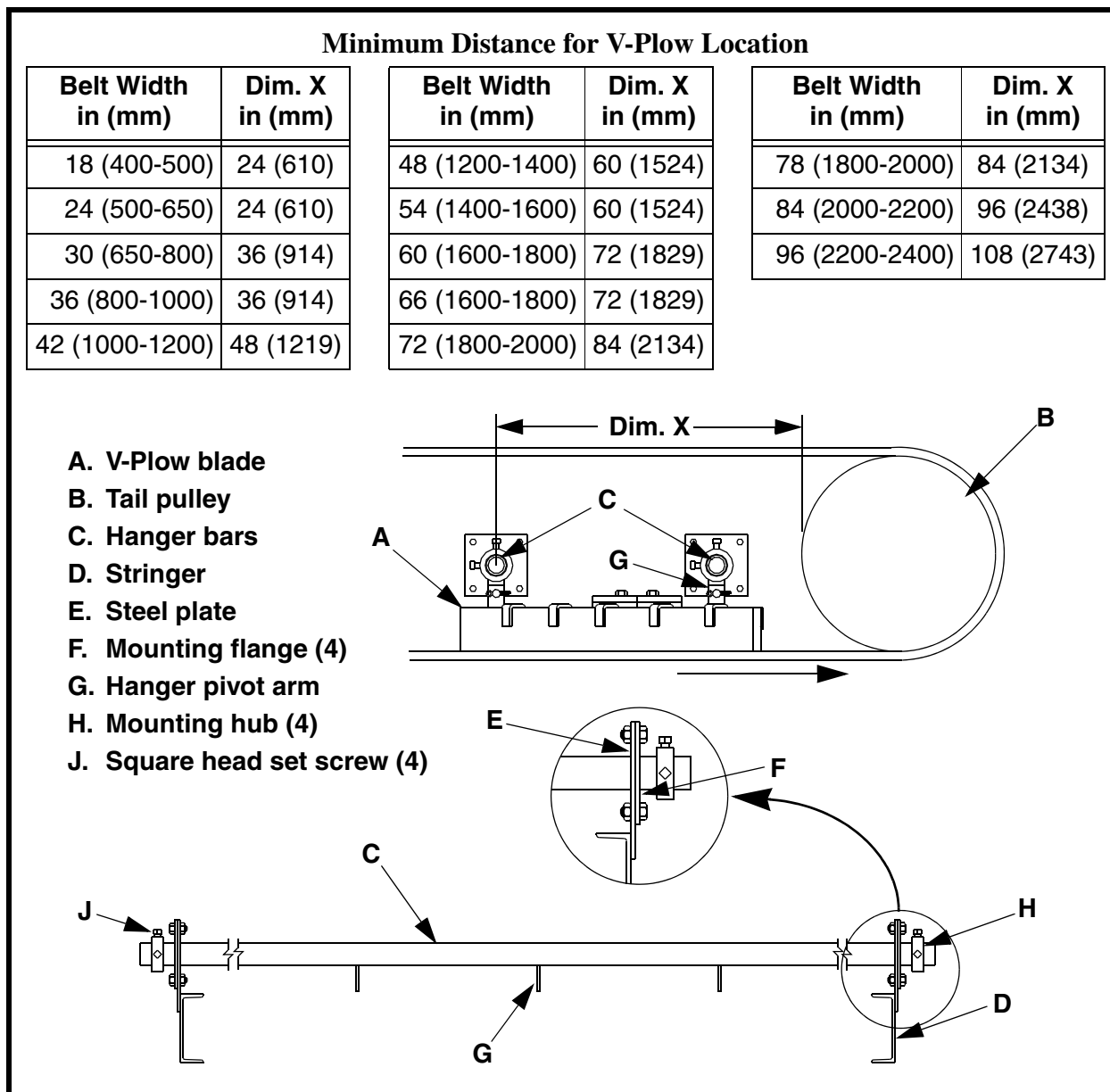

Figure 1. Locating Martin® V-Plow HD on Belt

2. Locate the hanger bars according to Table II and Figure 2. Mark the location of the hanger bars on the stringers.
3. Determine how to mount the hanger bars:
 - a. If the stringers are too low to accommodate the hanger bars in the proper position, bolt or weld four 1/2-in. (13-mm) thick steel plates to the top of the stringers.
 - b. If the stringers are high enough to accommodate the hanger bars in the proper position, mount the mounting flanges for hanger bars directly onto the stringers.

**Table II. Martin® V-Plow HD Hanger Bar Locations—in. (mm)
(Refer to Figure 2.)**

Hanger Pivot Arm Part No.	If arm length is A, locate hanger bar between B and C		
	A	B (min.)	C (max.)
31131*	2.12 (54)	6.50 (165)	7.25 (184)
31131-01*	5.37 (136)	9.75 (248)	10.50 (267)
31131-02	8.37 (213)	12.75 (324)	13.50 (343)
31131-03	12.50 (318)	16.88 (429)	17.63 (448)
31131-04	7.38 (187)	11.75 (298)	12.50 (318)
31131-05	5.75 (146)	10.13 (257)	10.88 (276)
31131-06	6.88 (175)	11.25 (286)	12.00 (305)
31131-07	9.88 (251)	14.25 (362)	15.00 (381)

*For full wear with clearance between metal frame and belt, locate at B (min.).

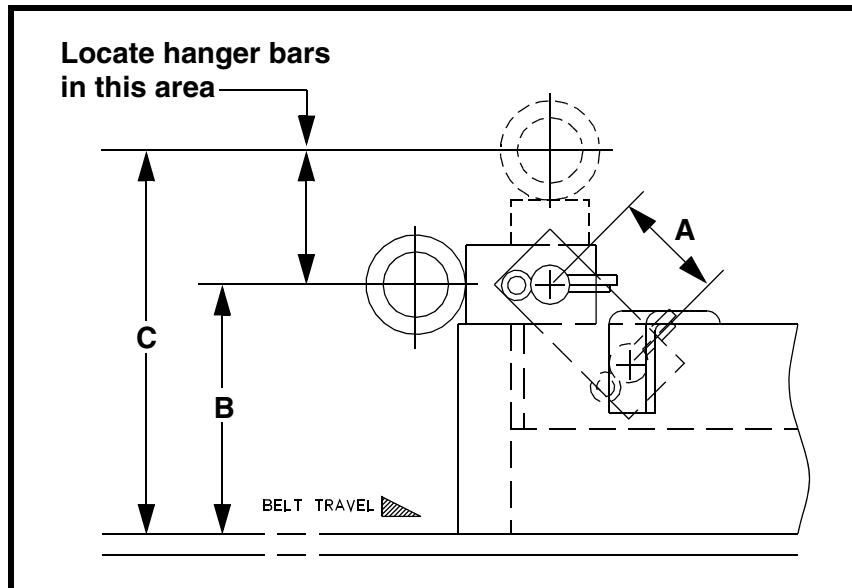

**Figure 2. Martin® V-Plow HD Hanger Bar Locations
(Refer to Table II.)**

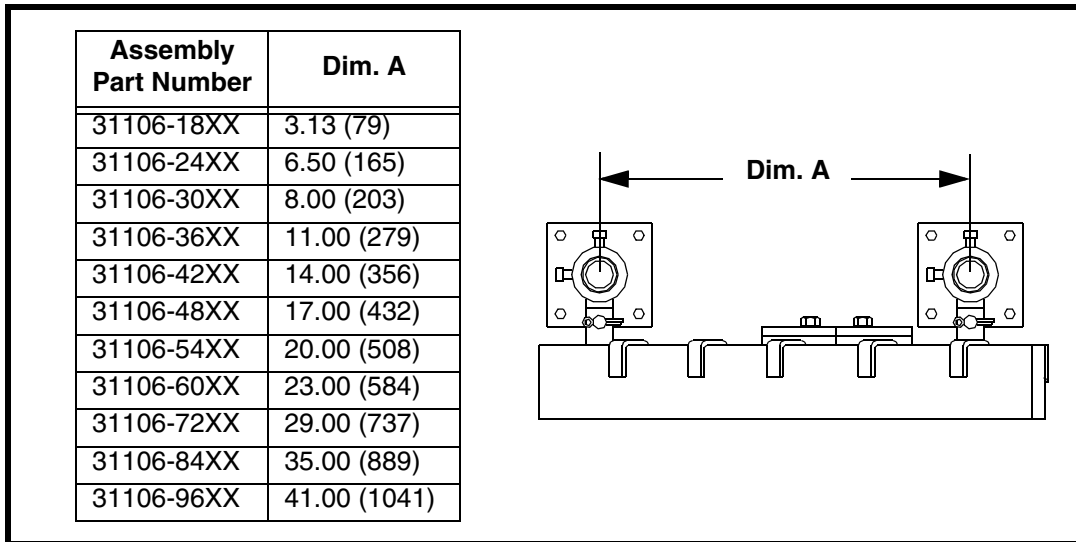

Figure 3. Distance Between Hanger Bars

4. Use a mounting flange as a template to mark the location of mounting holes on the stringers or steel plates on both sides of the belt for each hanger bar.

NOTE

For easier maintenance, Martin Engineering recommends bolting rather than welding mounting flanges to stringers or steel plates.

5. Bolt or weld the mounting flanges to the stringers or steel plates as follows:
 - a. If bolting the mounting plates to stringers or steel plates, do the following:
 - (1) Drill or cut four 2-1/2-in. (63-mm) holes for the two hanger bars.
 - (2) Drill or cut four 9/16-in. (14-mm) holes for the mounting screws for each mounting flange.
 - (3) Remove burrs and sharp edges.
 - (4) Install each mounting flange onto the stringer or steel plate with four hex head cap screws, flat washers, compression washers, and hex nuts.
 - b. If welding the mounting plates to stringers or steel plates, do the following:
 - (1) Drill or cut four 2-1/2-in. (63-mm) holes for the two hanger bars.
 - (2) Position each mounting flange onto the stringer or steel plate.
 - (3) Weld each mounting flange onto the stringer or steel plate. Make a continuous weld around the entire mounting flange.

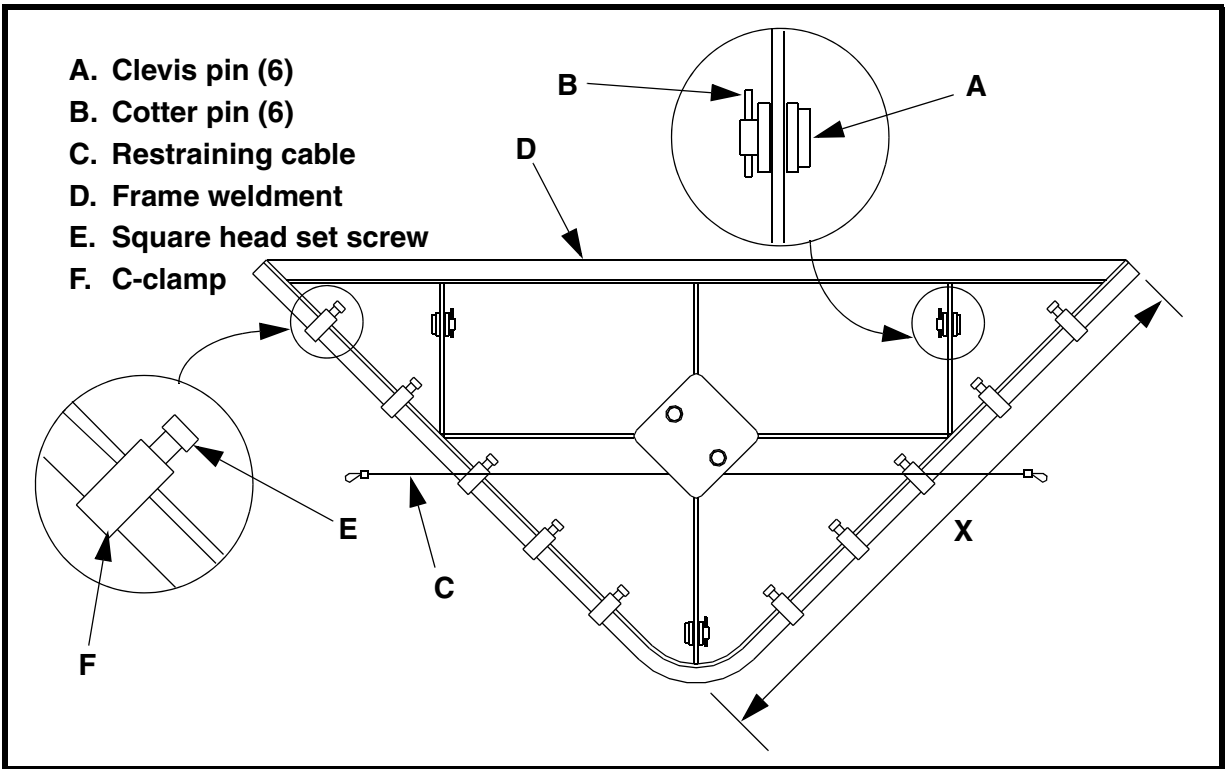

Figure 4. Installing Martin® V-Plow HD

6. Insert the hanger bars (C, Figure 1) through the mounting holes. Attach each hanger pivot arm (G) to the hanger bar with a clevis pin (A, Figure 4) and cotter pin (B).
7. Center the blade on the belt. Slide a mounting hub (H, Figure 1) onto both ends of each hanger bar, and up against the mounting flanges. Tighten the two set screws (J) in each mounting hub.

CAUTION

Restraining cables must be installed to prevent the plow from being carried into the pulley if the mount brackets should fail. Failure to install restraining cables could severely damage the plow, pulley, and belt. Do not install restraining cables on stringers that are between the plow and tail pulley.

8. Attach a restraining cable (C, Figure 4) to the conveyor stringers far enough from the tail pulley. Make sure v-plow is located according to chart in Figure 1. Leave no more than 2 in. (51 mm) of slack in cable.

After Installing V-Plow

IMPORTANT

Read entire section before beginning work.

1. Thoroughly wipe the outside chute wall clean above the v-plow on the operator side of the chute. Place a Conveyor Products Warning Label (P/N 23395) and a Flying Objects Warning Label (P/N 38227) on the chute wall visible to the belt operator.

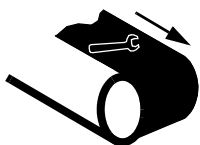

⚠ WARNING

Failure to remove tools from installation area and conveyor belt before turning on energy source can cause serious injury to personnel and damage to belt.

2. Remove all tools and the fire-retardant cover from the installation area and conveyor belt.



⚠ DANGER

Do not touch or go near conveyor belt or conveyor accessories when conveyor belt is running. Body or clothing can get caught and pull body into conveyor belt, causing severe injury or death.

3. Turn on the conveyor belt for 1 hour.



⚠ WARNING

Before adjusting belt cleaner, turn off and lock out/tag out energy source to conveyor belt and conveyor accessories.

4. After 1 hour of operation, turn off and lock out/tag out energy source according to ANSI standards (see “References”).
5. Make sure all fasteners are tight. Tighten if necessary.
6. Inspect the V-Plow for wear. (A small amount of “break-in” wear may be found. This will stop once the blade wears to the conveyor belt contour.)
7. Make sure the plow is pushing material off the edge of the belt efficiently, leaving minimal material on the belt.
8. Repeat step 2.

Monthly Maintenance

IMPORTANT

Read entire section before beginning work.



⚠ WARNING

Before servicing v-plow, turn off and lock out/tag out energy source to conveyor belt and conveyor accessories.

1. Turn off and lock out/tag out energy source according to ANSI standards (see “References”).
2. Make sure all fasteners are tight. Tighten if necessary.
3. Check the cleaning edge for wear. If it is worn almost to the frame weldment (D, Figure 4), replace as follows:
 - a. Remove the square head set screws (E) and C-clamps (F) holding the cleaning edge against the frame weldment.
 - b. Remove the old cleaning edge.
 - c. Install a new cleaning edge and secure with C-clamps and square head set screws.
4. Check the restraining cable for wear. Make sure the cable is securely attached to the stringers.
5. Wipe all labels clean. If the labels are not readable, contact Martin Engineering or your representative for replacements.

⚠ WARNING

Failure to remove tools from installation area and conveyor belt before turning on energy source can cause serious injury to personnel and damage to belt.

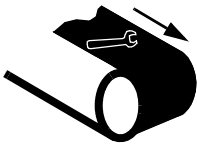

6. Remove all tools from the maintenance area.

⚠ DANGER

Do not touch or go near conveyor belt or conveyor accessories when conveyor belt is running. Body or clothing can get caught and pull body into conveyor belt, causing severe injury or death.



7. Start the conveyor belt.

Part Numbers

This section provides product names and corresponding part numbers for the Martin® V-Plow HD and related equipment. Please reference the part numbers when ordering parts.

Martin® V-Plow HD Assembly

For belts 18 to 48 in. wide: P/N 31106-XXXX. See Figure 5.

For belts 54 to 96 in. wide: P/N 31106-XXXX. See Figure 6.

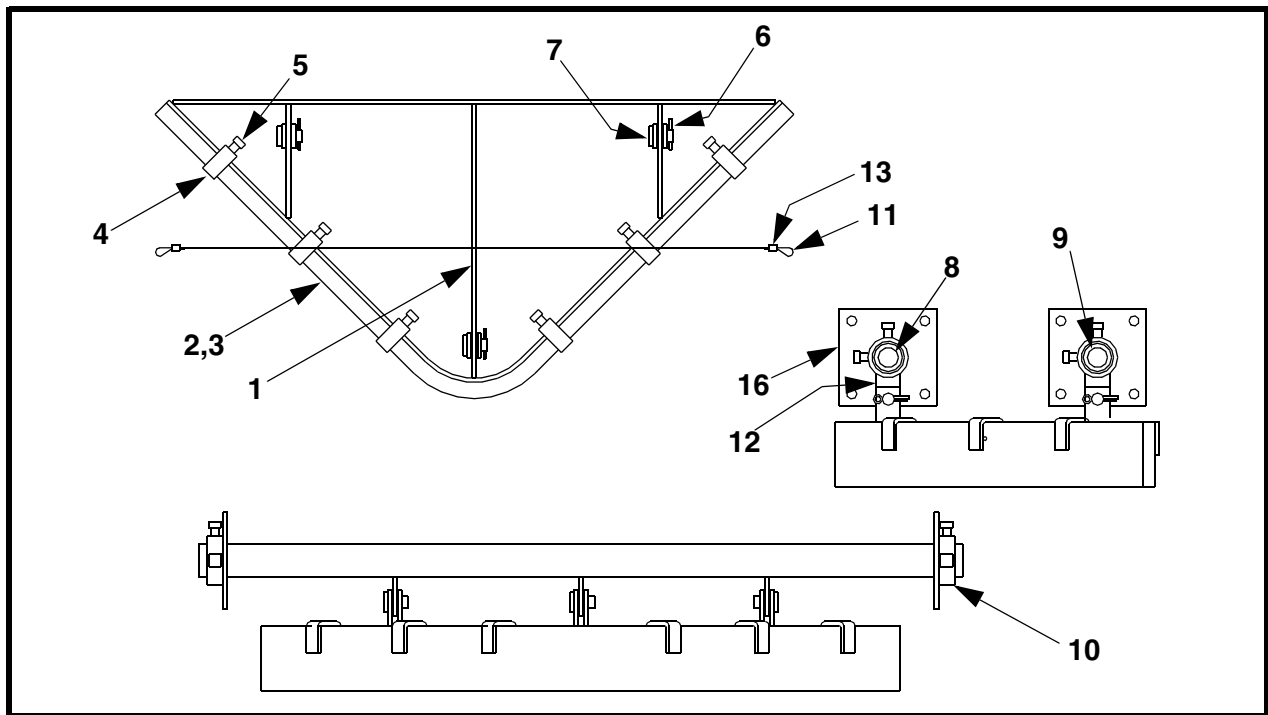

Item	Description	Part No.	Qty
1	Frame Weldment	31135-XX	1
2	Blade Urethane	Table VII	Table IV
3	Blade 800 Nitrile Rubber	100066	Table IV
4	C-Clamp	31132	Table III
5	Screw SHS 1/2-13NC x 1	22763-03	Table III
6	Pin Cotter	16578	6
7	Pin Clevis	29066	6
8	Bar Front Hanger	31136-XX	1
9	Bar Back Hanger	31133-XX	1
10	Hub Mounting	16845	4
11	Clip Cable	23481	4
12	Arm Hanger Pivot	Table VIII	6
13	Lanyard	100107	Table III
14 (NS)	Conveyor Products Warning Label	23395	2
15 (NS)	Operator's Manual	M3201	1
16 (NS)	Flange Mounting	Table III	4
17 (NS)	Mounting Hardware Kit	Table III	1
18 (NS)	Martin Products Label	32238	2
19 (NS)	Flying Objects Warning Label	38227	2

**Figure 5. Martin® V-Plow HD Assembly, P/N 31106-XXXX*
(18 - 48-in. [400 - 1400-mm] belts)**

*First XX indicates belt width (18 through 48 in.); third X indicates urethane or rubber blade; fourth X indicates special pivot arm heights (blank indicates standard height); last XX indicates material for urethane blades. **XX indicates belt width in inches.

Table III. Martin® V-Plow HD Item Quantities and Part Numbers

Assembly Part No.	Items 4 & 5 Qty	Item 13 Qty	Item 8 Part No.	Item 16 Part No.	Item 17 Part No.
31106-18XXXX	4	5' 0"	31136-24	30208	38735-1
31106-24XXXX	4	5' 0"	31136-24	16628	38735
31106-30XXXX	6	5' 8"	31136-36	16628	38735
31106-36XXXX	6	5' 8"	31136-36	16628	38735
31106-42XXXX	8	6' 10"	31136-48	16628	38735
31106-48XXXX	8	6' 10"	31136-48	16628	38735

Table IV. Martin® V-Plow HD Blade Quantities

Assembly Part No.	Item 2 Qty	Item 3 Qty
31106-18RX	0	2.25
31106-18UXXX	1	0
31106-24RX	0	2.96
31106-24UXXX	1	0
31106-30RX	0	3.67
31106-30UXXX	1	0
31106-36RX	0	4.37
31106-36UXXX	1	0
31106-42RX	0	5.08
31106-42UXXX	1	0
31106-48RX	0	5.79
31106-48UXXX	1	0

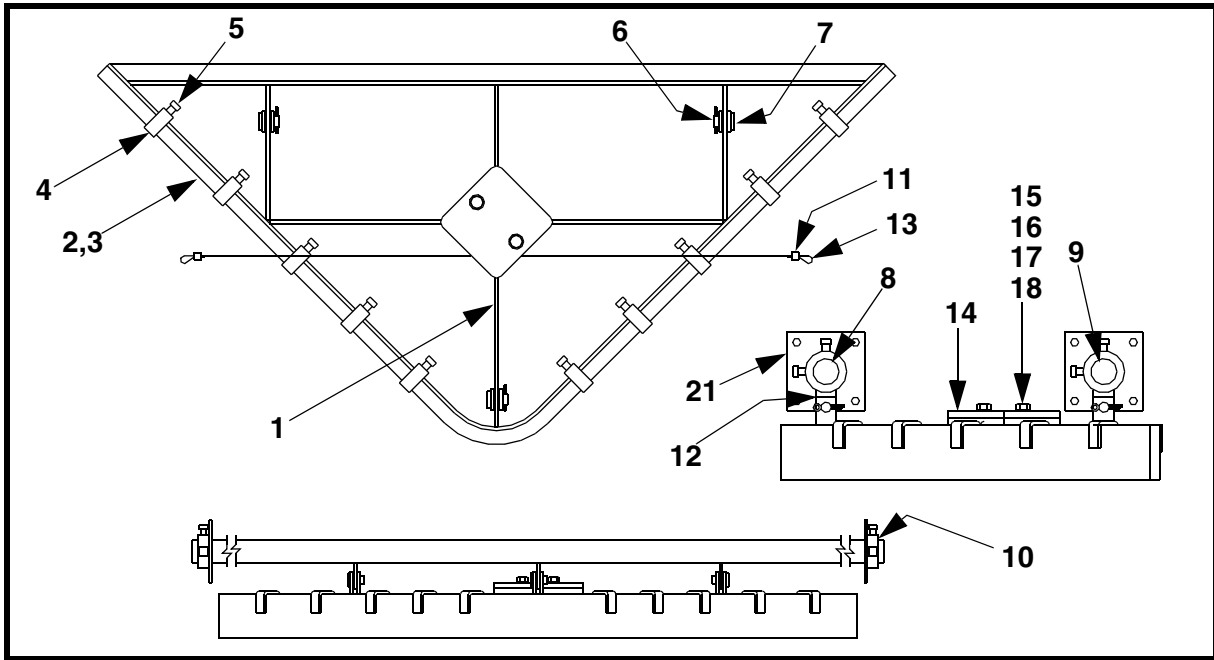

Item	Description	Part No.	Qty
1	Frame Weldment	31135-XX	1
2	Blade Urethane	Table VII	Table VI
3	Blade 800 Nitrile Rubber	100066	Table VI
4	C-Clamp	31132	Table V
5	Screw SHS 1/2-13NC x 1	22763-03	Table V
6	Pin Cotter	16578	6
7	Pin Clevis	29066	6
8	Bar Front Hanger	31136-XX	1
9	Bar Back Hanger	31133-XX	1
10	Hub Mounting	16845	4
11	Clip Cable	23481	4
12	Arm Hanger Pivot	Table VIII	6
13	Lanyard	100107	Table V
14	Weight 5 lbs Stackable	28817	Table V
15	Screw HHC 1/2-13NC	Table V	2
16	Nut Hex 1/2-13NC	11771	2
17	Washer Compression 1/2	11750	2
18	Washer Flat 1/2	31010	2
19 (NS)	Conveyor Products Warning Label	23395	2
20 (NS)	Operator's Manual	M3201	1
21 (NS)	Flange Mounting	16628	4
22 (NS)	Mounting Hardware Kit	38735	1
23 (NS)	Martin Products Label	32238	2
24 (NS)	Flying Objects Warning Label	38227	2

**Figure 6. Martin® V-Plow HD Assembly, P/N 31106-XXXXXX*
(54 - 96-in. [1400 - 2400-mm] belts)**

*First XX indicates belt width (54 through 96 in.); third X indicates urethane or rubber blade; fourth X indicates special pivot arm heights (blank indicates standard height); last XX indicates material for urethane blades. **XX indicates belt width in inches.

Table V. Martin® V-Plow HD Item Quantities and Part Numbers

Assembly Part No.	Items 4 & 5 Qty	Item 13 Qty	Item 8 Part No.	Item 17 Part No.
31106-54XXXX	10	8' 0"	31136-60	30224
31106-60XXXX	10	8' 0"	31136-60	30224
31106-66XXXX	12	9' 2"	31136-72	30224
31106-72XXXX	12	9' 2"	31136-72	30224
31106-78XXXX	14	9' 7"	31136-84	M921
31106-84XXXX	14	9' 7"	31136-84	M921
31106-96XXXX	16	10' 10"	31136-96	M921

Table VI. Martin® V-Plow HD Blade Quantities

Assembly Part No.	Item 2 Qty	Item 3 Qty
31106-54RX	0	6.50
31106-54UXXX	1	0
31106-60RX	0	7.21
31106-60UXXX	1	0
31106-66RX	0	7.92
31106-66UXXX	1	0
31106-72RX	0	8.62
31106-72UXXX	1	0
31106-78RX	0	9.33
31106-78UXXX	1	0
31106-84RX	0	10.04
31106-84UXXX	1	0
31106-96RX	0	11.46
31106-96UXXX	1	0

Table VII. Martin® V-Plow HD Urethane Blade Chart

Assembly Part No.	Item 2 Part No.	Blade Material	Blade Color
31106-XXXX	31134-XXU	90 Durometer	Orange
31106-XXUXGR	31134-XXUGR	95 Durometer	Green
31106-XXUXBL	31134-XXUBL	85 Durometer	Blue
31106-XXUXBR	31134-XXUBR	85 Durometer	Brown

Table VIII. Martin® V-Plow HD Hanger Pivot Arm Part Numbers

Assembly Part No.	Pivot Arm Part No.	Pivot Arm Length in (mm)
31106-XXX	31131	2.12 (54)
31106-XXX1	31131-01	5.37 (136)
31106-XXX2	31131-02	8.37 (213)
31106-XXX3	31131-03	12.50 (318)
31106-XXX4	31131-04	7.38 (187)
31106-XXX5	31131-05	5.75 (146)
31106-XXX6	31131-06	6.88 (175)
31106-XXX7	31131-07	9.88 (251)

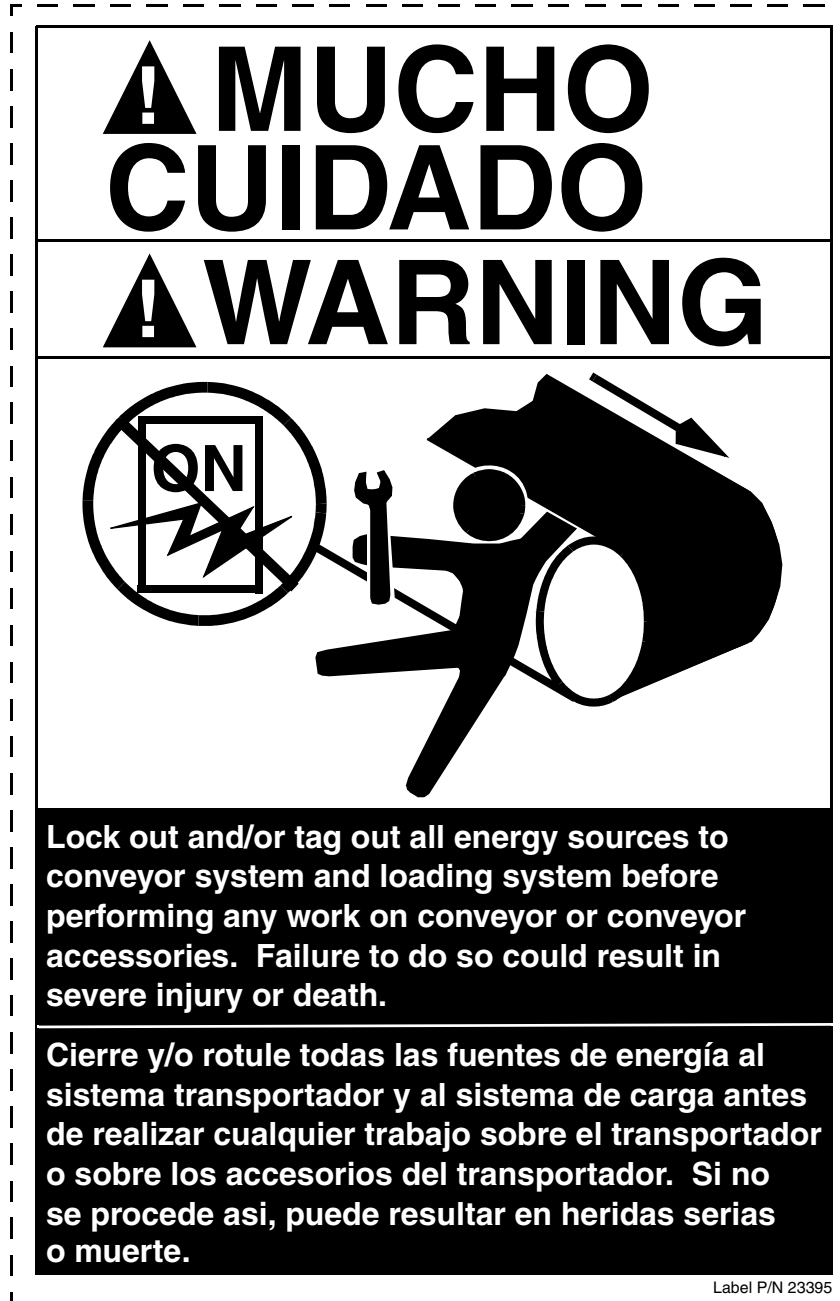

Figure 7. Conveyor Products Warning Label, P/N 23395



Figure 8. Flying Objects Warning Label, P/N 38227